

# 扁平吸盘 (圆形)



## 扁平吸盘 PFTN

吸附面积 (Ø) 1 mm 至 200 mm



扁平吸盘 PFTN

**应用：**通用圆形真空吸盘有多种材质可选，满足多种搬运作业需求；特别适合搬运平整、光滑表面的工件。

### 亮点

- 众多材质可选
- 多种直径可选
- 最优结构设计
- 内部容积小
- 底部支撑结构

### 优势

- > 真空吸盘用途广泛 (耐高温、防静电、无痕、耐化学腐蚀)
- > 尺寸多样，几乎适用于所有工件
- > 尺寸小、吸力大
- > 超短作业周期
- > 搬运薄壁工件不会产生永久变形

## 扁平吸盘 PFTN 订购指南

PFTN		20		- NBR-55		- G1/8-AG			
吸盘代码	描述	吸盘直径 <sup>(1)</sup>		橡胶件		连接头螺纹 <sup>(2)</sup>			
代码	描述	代码	直径	代码	材质/颜色	代码	螺纹		
PF	不带吸盘接头	1	Ø 1.0 mm	30	Ø 28.8 mm	NBR-55	丁腈橡胶	无	不带吸盘接头
PFTN	带吸盘接头	1.5	Ø 1.5 mm	35	Ø 35.0 mm	NBR-AS-55	丁腈橡胶 (防静电)	M3-AG	M3外螺纹
		2	Ø 2.0 mm	40	Ø 40.0 mm	SI-55	硅橡胶	M5-AG	M5外螺纹
		3.5	Ø 3.5 mm	50	Ø 50.0 mm	SI-AS-55	硅橡胶 (防静电)	M5-IG	M5内螺纹
		5	Ø 5.0 mm	60	Ø 60.0 mm	HT1-60	无痕橡胶	G1/8-AG	G1/8外直螺纹
		6	Ø 6.0 mm	80	Ø 80.0 mm	FPM-65	氟碳橡胶	G1/8-IG	G1/8内直螺纹
		8	Ø 8.0 mm	95	Ø 95.0 mm	PU-55	聚氨酯	R1/8-AG	R1/8内锥螺纹
		10	Ø 10.0 mm	120	Ø 120.0 mm			G1/4-AG	G1/4外直螺纹
		15	Ø 15.0 mm	150	Ø 147.5 mm			G1/4-IG	G1/4内直螺纹
		20	Ø 20.0 mm	200	Ø 193.0 mm			R1/4-AG	R1/4内锥螺纹
		25	Ø 25.0 mm					G1/2-IG	G1/2内直螺纹

<sup>(1)</sup>吸盘直径和螺纹型号的可用组合请参见“订购参数”。

<sup>(2)</sup>由于外锥螺纹R可装配在内直螺纹G上，因此未列出内锥螺纹Rc。

## 扁平吸盘 PFTN 技术参数

型号	吸力 [N]*	内部体积 [cm³]	工件最小曲率半径 [mm](凸形)	推荐软管直径 [mm]	接头类型
PFTN 1	0,03	0,001	2	2	N 001
PFTN 1.5	0,06	0,001	2	2	N 002
PFTN 2	0,12	0,001	2	2	N 003
PFTN 3.5	0,42	0,002	8	2	N 003
PFTN 5	0,75	0,005	8	2	N 004
PFTN 6	1,20	0,008	8	2	N 004
PFTN 8	2,30	0,030	10	2	N 004
PFTN 10	4,00	0,070	13	2	N 004
PFTN 15	9,00	0,400	13	4	N 005
PFTN 20	15,50	0,800	20	4	N 006
PFTN 25	26,50	1,300	25	4	N 007
PFTN 30	34,00	1,300	40	4	N 007
PFTN 35	44,00	2,700	50	4	N 007
PFTN 40	57,70	3,800	50	4	N 007
PFTN 50	91,00	7,000	75	4	N 008
PFTN 60	125,00	10,000	100	6	N 009
PFTN 80	260,00	25,000	150	6	N 009
PFTN 95	350,00	35,000	200	6	N 009
PFTN 120	540,00	77,800	300	9	N 010
PFTN 150	842,00	176,300	300	9	N 010
PFTN 200	1498,00	427,000	400	9	N 010

\*指定的吸力为理论值，真空度为-0.6 bar，光滑、干燥表面的工件，不包括安全系数

# 扁平吸盘

PF/ PFTN

适用于多种工件搬运作业的真空吸盘



## 扁平吸盘 PFTN 订购编号

吸盘 PFTN (橡胶部件 + 接头) 未组装供货；直径 120 mm 以上的吸盘 PFTN 组装后成套供货。供货产品包括：

- 吸盘垫 PF — 橡胶部件，提供不同材质及不同直径的尺寸规格
- 接头 SA-NIP — 提供各种螺纹

可选备件：吸盘垫 PF、接头 SA-NIP

## 扁平吸盘 PFTN

型号	吸盘材质 * / 肖氏硬度 A		丁腈橡胶 NBR 55±5ShA	丁腈橡胶 NBR-防静电 55±5ShA	聚氨脂 PU 55±5ShA	硅橡胶 SI 55±5ShA	硅橡胶 SI-防静电 55±5ShA
	氟橡胶 FPM 65±5ShA	高温材料 HT1 60±5ShA					
PFTN1.0-M3-AG	-	-	100001	100002	-	100003	-
PFTN1.5-M3-AG	-	-	100005	100006	-	100007	-
PFTN2.0-M3-AG	-	-	100008	100009	-	100010	-
PFTN3.5-M3-AG	100012	-	100013	100014	-	100015	100016
PFTN5.0-M5-AG	100017	100018	100019	100020	-	100021	100022
PFTN5.0-M5-IG	100023	100024	100025	100026	-	100027	100028
PFTN6.0-M5-AG	100029	100030	100031	100032	-	100033	100034
PFTN6.0-M5-IG	100035	100036	100037	100038	-	100039	100040
PFTN8.0-M5-AG	100041	100042	100043	100044	100053	100045	100046
PFTN8.0-M5-IG	100047	100048	100049	100050	100054	100051	100052
PFTN10- M5-AG	100055	100056	100057	100058	100067	100059	100060
PFTN10- M5-IG	100061	100062	100063	100064	100068	100065	100066
PFTN10- G1/8-AG	100069	100070	100071	100072	100081	100073	100074
PFTN10- G1/8-IG	100075	100076	100077	100078	100082	100079	100080
PFTN15- G1/8-AG	100088	100090	100092	100094	100106	100096	100098
PFTN15- G1/8-IG	100100	100101	100102	100103	100107	100104	100105
PFTN20- G1/8-AG	100108	100110	100112	100114	100123	100116	-
PFTN20- G1/8-IG	100118	100119	100120	100121	100124	100122	-
PFTN25- G1/8-AG	100125	100127	100129	100131	100140	100133	-
PFTN25- G1/8-IG	100135	100136	100137	100138	100142	100139	-
PFTN30- G1/8-AG	100143	100145	100147	100149	100158	100151	-
PFTN30- G1/8-IG	100153	100154	100155	100156	100160	100157	-
PFTN35- G1/8-AG	100161	100163	100165	100167	100176	100169	-
PFTN35- G1/8-IG	100171	100172	100173	100174	100178	100175	-
PFTN40- G1/8-AG	100179	100181	100183	100185	100194	100187	-
PFTN40- G1/8-IG	100189	100190	100191	100192	100196	100193	-
PFTN50- G1/8-AG	100197	100199	100201	100203	100212	100205	-
PFTN50- G1/8-IG	100207	100208	100209	100210	100214	100211	-
PFTN60- G1/4-AG	100215	100217	100219	-	100227	100221	-
PFTN60- G1/4-IG	100223	100224	100225	-	100229	100226	-
PFTN80- G1/4-AG	100230	100232	100234	-	100242	100236	-
PFTN80- G1/4-IG	100238	100239	100240	-	100244	100241	-
PFTN95- G1/4-AG	100245	-	100247	-	100254	100249	-
PFTN95- G1/4-IG	100251	-	100252	-	100256	100253	-
PFTN 120- G1/2-IG	100257	-	100259	-	-	100261	-
PFTN 150- G1/2-IG	-	-	100263	-	-	100265	-
PFTN200- G1/2-IG	-	-	100267	-	-	100269	-

\* 参见“材质性能表”以了解更多的信息

# 扁平吸盘 (圆形)



## 扁平吸盘 PFTN

吸附面积 (Ø) 1 mm 至 200 mm

### 扁平吸盘 PFTN 吸盘垫备件订购编号

型号	吸盘材质 * / 肖氏硬度 A						
	氟橡胶 FPM 65±5ShA	高温材料 HT1 60±5ShA	丁腈橡胶 NBR 55±5ShA	丁腈橡胶 NBR-抗静电 55±5ShA	聚氨酯 PU 55±5ShA	硅橡胶 SI 55±5ShA	硅橡胶 SI-抗静电 55±5ShA
PF 1	-	-	100271	100272	-	100273	-
PF 1.5	-	-	100274	100275	-	100276	-
PF 2	-	-	100277	100278	-	100279	100280
PF 3.5	100281	-	100282	100283	-	100284	100285
PF 5	100286	100287	100288	100289	-	100290	100291
PF 6	100292	100293	100294	100295	-	100296	100297
PF 8	100298	100299	100300	100301	100302	100303	100304
PF 10	100305	100306	100307	100308	100309	100310	100311
PF 15	100089	100091	100093	100095	100312	100097	100099
PF 20	100109	100111	100113	100115	100313	100117	-
PF 25	100126	100128	100130	100132	100141	100134	-
PF 30	100144	100146	100148	100150	100159	100152	-
PF 35	100162	100164	100166	100168	100177	100170	-
PF 40	100180	100182	100184	100186	100195	100188	-
PF 50	100198	100200	100202	100204	100213	100206	-
PF 60	100216	100218	100220	-	100228	100222	-
PF 80	100231	100233	100235	-	100243	100237	-
PF 95	100246	-	100248	-	100255	100250	-
PF 120	100258	-	100260	-	-	100262	-
PF 150	-	-	100264	-	-	100266	-
PF 200	-	-	100268	-	-	100270	-

\*参见“材质性能表”以了解更多的信息

### 扁平吸盘 PFTN 接头备件订购编号

型号	吸盘接头 [AG]		吸盘接头 [IG]			止动螺纹	
PFTN 1 M3	SA-NIP N001 M3-AG	100314	-	-	-	-	-
PFTN 1.5 M3	SA-NIP N002 M3-AG	100315	-	-	-	-	-
PFTN 2 M3	SA-NIP N003 M3-AG	100316	-	-	-	-	-
PFTN 3.5 M3	SA-NIP N003 M3-AG	100316	-	-	-	-	-
PFTN 5 M5	SA-NIP N004 M5-AG	100317	SA-NIP N004 M5-IG	100324	-	-	-
PFTN 6 M5	SA-NIP N004 M5-AG	100317	SA-NIP N004 M5-IG	100324	-	-	-
PFTN 8 M5	SA-NIP N004 M5-AG	100317	SA-NIP N004 M5-IG	100324	-	-	-
PFTN 10 M5	SA-NIP N004 M5-AG	100317	SA-NIP N004 M5-IG	100324	-	-	-
PFTN 10 G1/8	SA-NIP N004 G1/8-AG	100318	SA-NIP N004 G1/8-IG	100325	-	-	-
PFTN 15 G1/8	SA-NIP N005 G1/8-AG	100319	SA-NIP N005 G1/8-IG	100326	TN-PF-15-M5	102628	-
PFTN 20 G1/8	SA-NIP N006 G1/8-AG	100320	SA-NIP N006 G1/8-IG	100327	TN-PF-20-M5	102629	-
PFTN 25 G1/8	SA-NIP N007 G1/8-AG	100321	SA-NIP N007 G1/8-IG	100328	TN-PF-25-M6	102630	-
PFTN 30 G1/8	SA-NIP N007 G1/8-AG	100321	SA-NIP N007 G1/8-IG	100328	TN-PF-25-M6	102630	-
PFTN 35 G1/8	SA-NIP N007 G1/8-AG	100321	SA-NIP N007 G1/8-IG	100328	TN-PF-25-M6	102630	-
PFTN 40 G1/8	SA-NIP N007 G1/8-AG	100321	SA-NIP N007 G1/8-IG	100328	TN-PF-25-M6	102630	-
PFTN 50 G1/8	SA-NIP N008 G1/8-AG	100322	SA-NIP N008 G1/8-IG	100329	TN-PF-50-M6	102631	-
PFTN 60 G1/4	SA-NIP N009 G1/4-AG	100323	SA-NIP N009 G1/4-IG	100330	-	-	-
PFTN 80 G1/4	SA-NIP N009 G1/4-AG	100323	SA-NIP N009 G1/4-IG	100330	-	-	-
PFTN 95 G1/4	SA-NIP N009 G1/4-AG	100323	SA-NIP N009 G1/4-IG	100330	-	-	-
PFTN 120 G1/2	-	-	SA-NIP N010 G1/2-IG	100331	-	-	-
PFTN 150 G1/2	-	-	SA-NIP N010 G1/2-IG	100331	-	-	-
PFTN 200 G1/2	-	-	SA-NIP N010 G1/2-IG	100331	-	-	-

# 扁平吸盘

PF / PFTN

适用于多种工件搬运作业的的真空吸盘



## PFTN 结构参数

每组适配吸盘接头中，替换吸盘垫和吸盘接头可随意组合。



扁平吸盘PFTN结构设计

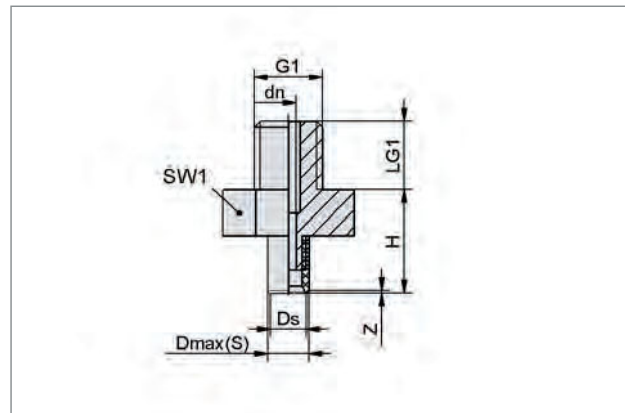

PFTN-1至1.5-AG

型号	尺寸[mm] <sup>(6)</sup>		Ds	G1	H	LG1	SW1	Z(行程)	重量 [g]
	dn	Dmax(S)							
PFTN1-...-M3-AG	0.4	1.2	1.0	M3-M	3.6	3	5	0.1	1
PFTN1.5-...-M3-AG	0.7	1.8	1.5	M3-M	4.5	3	5	0.1	1

<sup>(6)</sup>符合DIN ISO 3302-1 M3橡胶件允许尺寸公差。

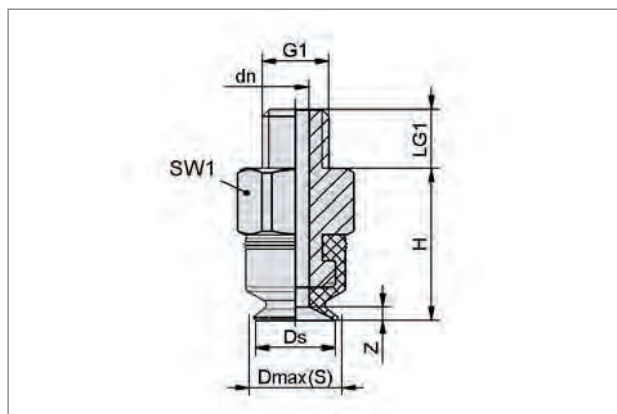

PFTN-2至10-AG

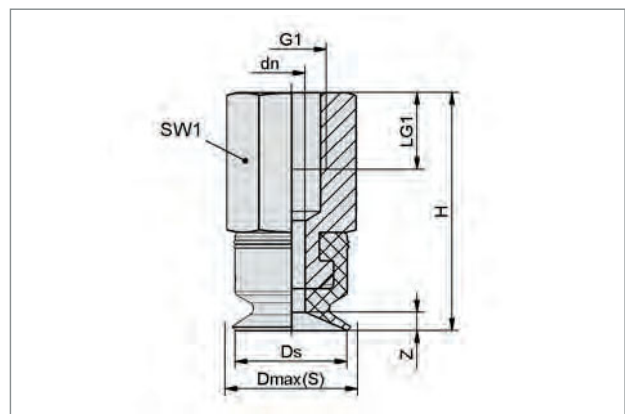

PFTN-5至10-IG

型号	尺寸[mm] <sup>(7)</sup>		Ds	G1	H	LG1	SW1	Z(行程)	重量 <sup>(8)</sup> [g]
	dn	Dmax(S)							
PFTN2-...-M3-AG	1.0	2.5	2.0	M3-AG	6.0	3.0	5	0.5	1
PFTN3.5-...-M3-AG	1.0	4.0	3.5	M3-AG	6.0	3.0	5	0.5	1
PFTN5-...-M5-AG	1.5	5.5	5.0	M5-AG	11.5	4.5	8	0.9	1
PFTN5-...-M5-IG	1.5	5.5	5.0	M5-IG	16.5	5.5	8	0.9	1
PFTN6-...-M5-AG	2.0	6.5	6.0	M5-AG	11.5	4.5	8	1.0	1
PFTN6-...-M5-IG	2.0	6.5	6.0	M5-IG	16.5	5.5	8	1.0	1
PFTN8-...-M5-AG	2.0	9.0	8.0	M5-AG	12.0	4.5	8	1.3	1
PFTN8-...-M5-IG	2.0	9.0	8.0	M5-IG	17.0	5.5	8	1.3	2
PFTN10-...-M5-AG	2.0	11.5	10.0	M5-AG	12.5	4.5	8	1.4	1
PFTN10-...-M5-IG	2.0	11.5	10.0	M5-IG	17.5	5.5	8	1.4	2
PFTN10-...-G1/8-AG	2.0	11.5	10.0	G1/8-AG	12.5	8.0	14	1.4	4
PFTN10-...-G1/8-IG	2.0	11.5	10.0	G1/8-IG	23.5	9.0	14	1.4	5

<sup>(7)</sup>符合DIN ISO 3302-1 M3橡胶件允许尺寸公差。

<sup>(8)</sup>材质FPM：重量值 x 1.2。

# 扁平吸盘

PF / PFTN

适用于多种工件搬运作业的的真空吸盘



## PFTN结构参数

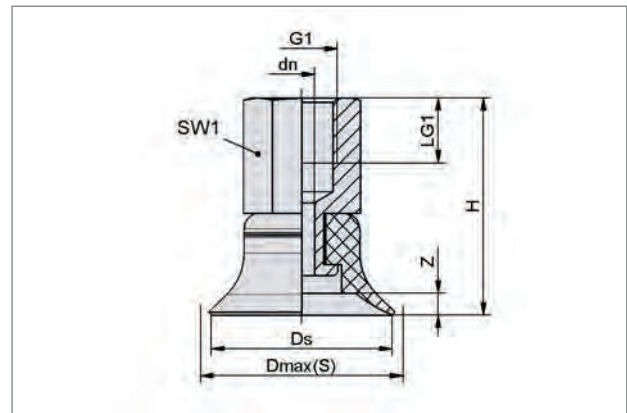
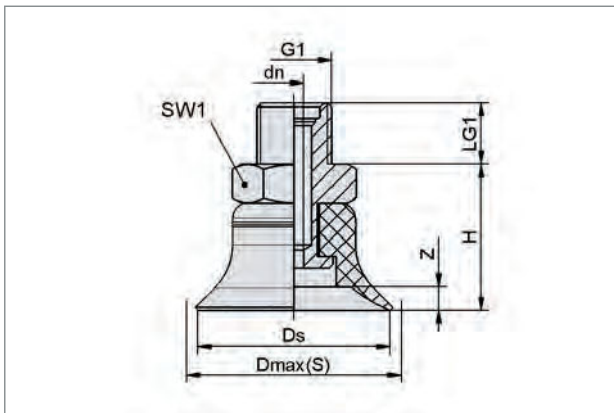

PFTN-15至50-...-AG

PFTN-15至50-...-IG

型号	尺寸[mm] <sup>(9)</sup>		Ds	G1		H	LG1	SW1	Z(行程)	重量 <sup>(10)</sup> [g]
	dn	Dmax(S)		直	螺纹					
PFTN15-...-1/8-AG	2.0	17.5	15.0	G1/8-AG	R1/8-AG	13	8	14	1.9	5
PFTN15-...-1/8-IG	2.0	17.5	15.0	G1/8-IG	-	24	9	14	1.9	6
PFTN20-...-1/8-AG	2.0	23.0	20.0	G1/8-AG	R1/8-AG	15	8	14	2.2	6
PFTN20-...-1/8-IG	2.0	23.0	20.0	G1/8-IG	-	26	9	14	2.2	7
PFTN25-...-1/8-AG	2.4	27.5	25.0	G1/8-AG	R1/8-AG	19	8	14	3.0	7
PFTN25-...-1/8-IG	3.5	27.5	25.0	G1/8-IG	-	30	9	14	3.0	9
PFTN30-...-1/8-AG	2.4	31.5	28.8	G1/8-AG	R1/8-AG	17	8	14	2.0	8
PFTN30-...-1/8-IG	3.5	31.5	28.8	G1/8-IG	-	28	9	14	2.0	9
PFTN35-...-1/8-AG	2.4	38.0	35.0	G1/8-AG	R1/8-AG	19	8	14	3.0	11
PFTN35-...-1/8-IG	3.5	38.0	35.0	G1/8-IG	-	30	9	14	3.0	12
PFTN40-...-1/8-AG	2.4	43.0	40.0	G1/8-AG	R1/8-AG	19	8	14	3.5	12
PFTN40-...-1/8-IG	3.5	43.0	40.0	G1/8-IG	-	30	9	14	3.5	14
PFTN50-...-1/8-AG	2.4	53.5	50.0	G1/8-AG	R1/8-AG	20	8	14	4.0	15
PFTN50-...-1/8-IG	3.5	53.5	50.0	G1/8-IG	-	31	9	14	4.0	17

<sup>(9)</sup>符合DIN ISO 3302-1 M3橡胶件允许尺寸公差。

<sup>(10)</sup>材质FPM：重量值 x 1.2。

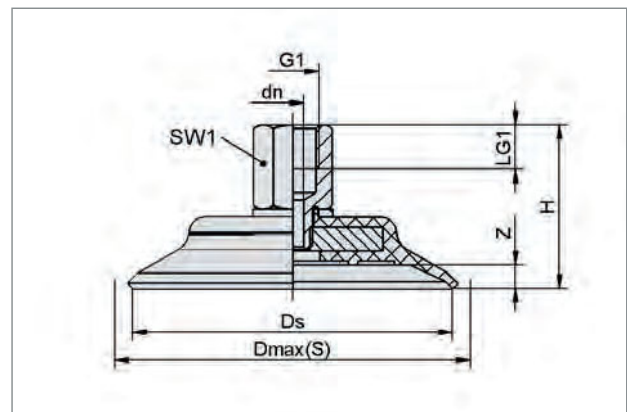
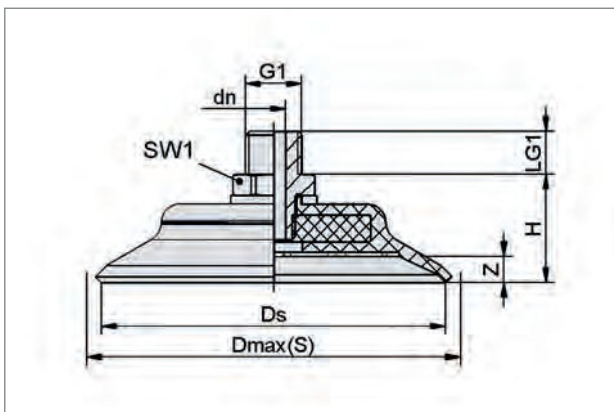

PFTN-60至95-...-AG

PFTN-60至95-...-IG

型号	尺寸[mm] <sup>(11)</sup>		Ds	G1		H	LG1	SW1	Z(行程)	重量 <sup>(12)</sup> [g]
	dn	Dmax(S)		直	螺纹					
PFTN60-...-1/4-AG	5.5	64	60	G1/4-AG	R1/4-AG	23.0	10	17	4.7	34
PFTN60-...-1/4-IG	5.5	64	60	G1/4-IG	-	39.0	11	17	4.7	37
PFTN80-...-1/4-AG	5.5	86	80	G1/4-AG	R1/4-AG	25.0	10	17	6.0	63
PFTN80-...-1/4-IG	5.5	86	80	G1/4-IG	-	41.0	11	17	6.0	65
PFTN95-...-1/4-AG	5.5	102	95	G1/4-AG	R1/4-AG	25.5	10	17	6.0	102
PFTN95-...-1/4-IG	5.5	102	95	G1/4-IG	-	41.5	11	17	6.0	105

<sup>(11)</sup>符合DIN ISO 3302-1 M3橡胶件允许尺寸公差。

<sup>(12)</sup>材质FPM：重量值 x 1.2。

# 扁平吸盘

PF / PFTN

适用于多种工件搬运作业的的真空吸盘



## PFTN结构参数

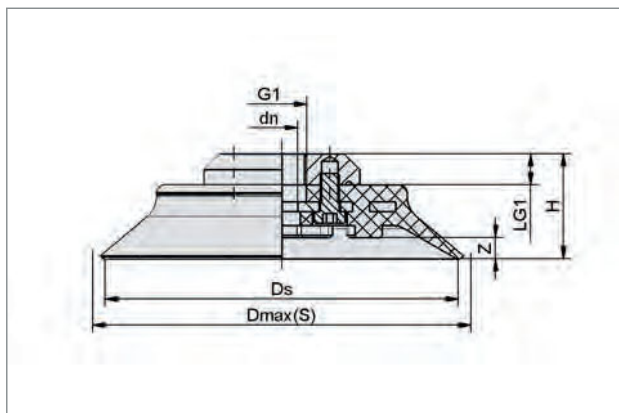

PFTN-120至200-...-IG

扁平真空吸盘PFTN用于搬运塑料板

型号	尺寸[mm] <sup>(13)</sup>			G1	H	LG1	Z(行程)	重量 <sup>(14)</sup> [g]
	dn	Dmax(S)	Ds					
PFTN-120-...-G1/2-IG	13,5	124	120,0	G1/2-IG	36,5	13	6	353
PFTN-150-...-G1/2-IG	13,5	158	147,5	G1/2-IG	45,5	13	9	521
PFTN-200-...-G1/2-IG	13,5	222	193,0	G1/2-IG	50,5	13	13	785

<sup>(13)</sup>符合DIN ISO 3302-1 M3橡胶件允许尺寸公差。

<sup>(14)</sup>材质FPM：重量值 x 1.2。

## PF结构参数

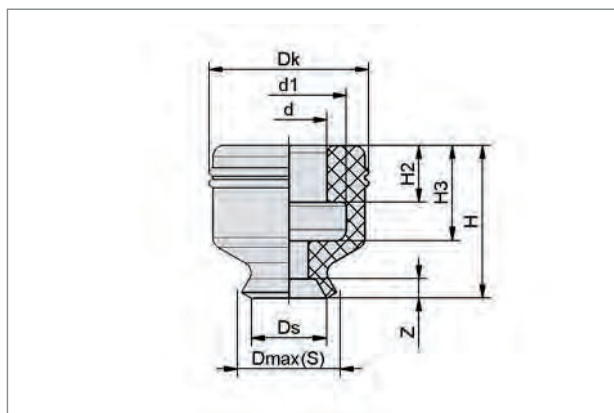
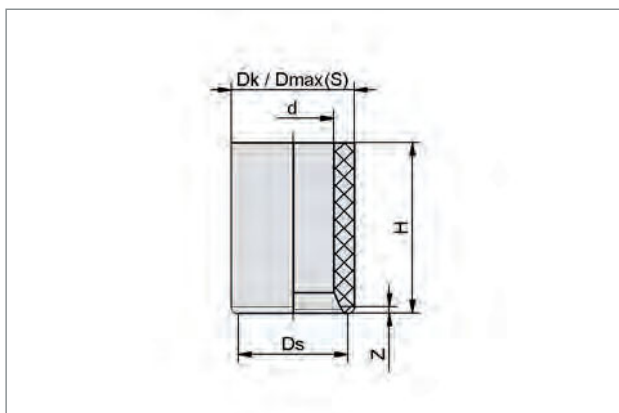

PF-1至PF-1.5

PF-2至PF-10

型号	尺寸[mm] <sup>(15)</sup>						H	H2	H3	Z(行程)	重量 <sup>(16)</sup> [g]
	d	d1	Dk	Dmax(S)	Ds	H					
PF1-...	0,8	-	1,2	1,2	1,0	1,6	-	-	0,1	0,01	
PF1.5-...	1,2	-	1,8	1,8	1,5	2,5	-	-	0,1	0,01	
PF2-...	2,0	3	4,2	3,0	2,0	4,0	1,5	2,5	0,5	0,02	
PF3.5-...	2,0	3	4,2	4,0	3,5	4,0	1,5	2,5	0,5	0,03	
PF5-...	4,0	6	7,7	5,5	5,0	6,5	2,0	4,0	0,9	0,15	
PF6-...	4,0	6	7,7	6,5	6,0	6,5	2,0	4,0	1,0	0,17	
PF8-...	4,0	6	8,2	9,0	8,0	7,0	2,0	4,0	1,3	0,23	
PF10-...	4,0	6	8,7	11,5	10,0	7,5	2,0	4,0	1,4	0,30	

<sup>(15)</sup>符合DIN ISO 3302-1 M3橡胶件允许尺寸公差。

<sup>(16)</sup>材质FPM：重量值 x 1.2。

# 扁平吸盘

PF / PFTN

适用于多种工件搬运作业的的真空吸盘



## PF结构参数

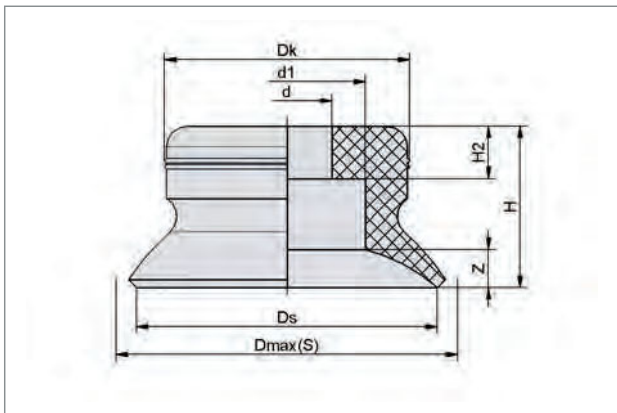

PF-15至PF-50

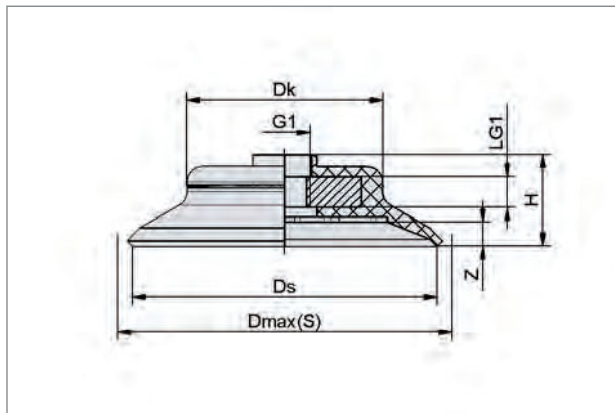

PF-60至PF-95

型号	尺寸[mm] <sup>(17)</sup>		Dk	Dmax(S)	Ds	G1	H	H2	LG1	Z(行程)	重量 <sup>(18)</sup> [g]
	d	d1									
PF-15-...	4.5	7.8	12.2	17.5	15.0	-	8.0	2.6	-	1.9	1
PF-20-...	4.5	11.0	15.2	23.0	20.0	-	10.0	4.5	-	2.2	1
PF-25-...	6.0	11.0	16.2	27.5	25.0	-	14.0	7.0	-	3.0	3
PF-30-...	6.0	11.0	15.1	31.5	28.8	-	12.0	7.0	-	2.0	3
PF-35-...	6.0	11.0	20.5	38.0	35.0	-	14.0	7.0	-	3.0	6
PF-40-...	6.0	11.0	24.3	43.0	40.0	-	14.0	7.0	-	3.5	7
PF-50-...	8.0	20.0	29.1	53.5	50.0	-	15.0	7.0	-	4.0	11
PF-60-...	-	-	38.7	64.0	60.0	M10x1.25-IG	18.0	-	6	4.7	25
PF-80-...	-	-	52.3	86.0	80.0	M10x1.25-IG	20.5	-	6	6.0	52
PF-95-...	-	-	68.2	102.0	95.0	M10x1.25-IG	19.0	-	6	6.0	93

<sup>(17)</sup>符合DIN ISO 3302-1 M3橡胶件允许尺寸公差。

<sup>(18)</sup>材质FPM：重量值 x 1.2。

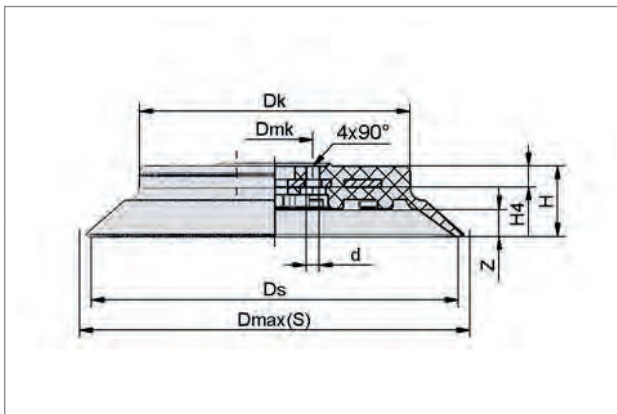

PF-120至PF-200

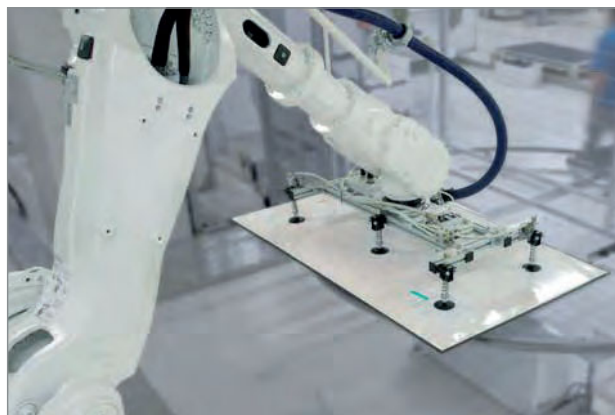

扁平真空吸盘PFTN搬运加工完成的塑料板材

型号	尺寸[mm] <sup>(19)</sup>					Ds	H	H4	Z(行程)	重量 <sup>(20)</sup> [g]
	d	Dk	Dmax(S)	Dmk	Ds					
PF-120-...	7.3	89.5	124	40	120.0	23.5	8.5	6	223	
PF-150-...	7.0	104.5	158	40	147.5	31.0	11.0	9	391	
PF-200-...	7.0	142.5	222	40	193.0	37.0	11.0	13	555	

<sup>(19)</sup>符合DIN ISO 3302-1 M3橡胶件允许尺寸公差。

<sup>(20)</sup>材质FPM：重量值x1.2。